

RIG#4

340K HYDRAULIC WORKOVER UNIT

Co-own with PT LEKOM MARAS



RIG#4

340K HYDRAULIC WORKOVER UNIT PACKAGE

HYDRAULIC POWER UNIT, RIG#4



Rig Name	Rig#4
Model	HWU 340K
Pulling Capacity	Max. 340,000 lbs
Snub Force	Max. 120,000 lbs
Jacking Stroke	Max. 10 ft
Working Pressure	3,000 psi
Working Depth	10,000 ft
Hydraulic Pressure	3,000 psi
Hydraulic Power Pack	Detroit Diesel Engine 8V92 Turbo Zone II
Hydraulic Power Pack HP	430 HP @ 1,800 RPM
Gin Pole	5.0 SWL c/w Tong Arm
Guywire Attachment Points	Yes

340K HYDRAULIC WORKOVER UNIT PACKAGE

HYDRAULIC POWER UNIT, RIG#4

Description	Specification
HWU 340K	<ul style="list-style-type: none"> • Jack 340,000 lbs • Work Window • Work Basket • Window Work Basket • Gin Pole SWL 5MT • Counter Balance Package • Sub Structure • Tong Arm • Rig Stairs • Rotary Table
Hydraulic Power Unit	Primary and Secondary Units (Detroit Diesel Engine 8V92 Turbo, 430 HP, Zone II)
Mud Pump	Primary Unit <ul style="list-style-type: none"> • Triplex Pump SPM 600 • Detroit Diesel Engine 8V92TA, 435 HP, Zone II • c/w 4-1/2" Plunger Secondary Unit <ul style="list-style-type: none"> • Triplex Pump Garden Denver • Detroit Diesel Engine 8V92TA, 450 HP, Zone II • c/w 4-1/2" plunger
Tank	<ul style="list-style-type: none"> • Mixing Tank 150 bbl c/w agitator (3 each) • Water Tank 150 bbl (1 each) • Trip Tank 25 bbl (2 each)
Shale Shaker	SWACO c/w 3HP Electrical Motor

340K HYDRAULIC WORKOVER UNIT PACKAGE

HYDRAULIC POWER UNIT, RIG#4



Hydraulic Power Pack

Engine	Zone 2 T3 Specification
Horse Power Rating	430 HP
Make /Type	Detroit Diesel 8V92 Turbo
Rating	Zone 2
Quantity	1 Primary + 1 Backup

340K HYDRAULIC WORKOVER UNIT PACKAGE ROTARY TABLE

- 11 500 ft /lbs torque high range at 2850 psi
- 22 000 ft /lbs torque low range at 2850 psi
- Rated 136 RPM
- Continuous operation
- 460 000 lbs compression load rating
- 230 000 lbs tension load rating
- Rotary Control Valve

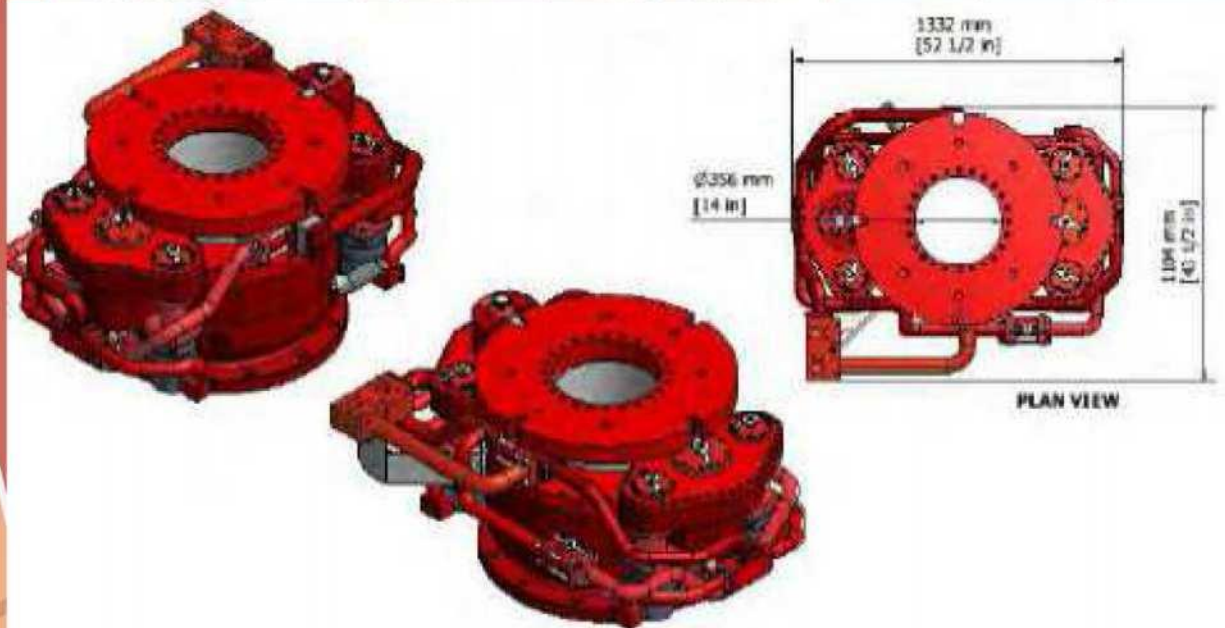
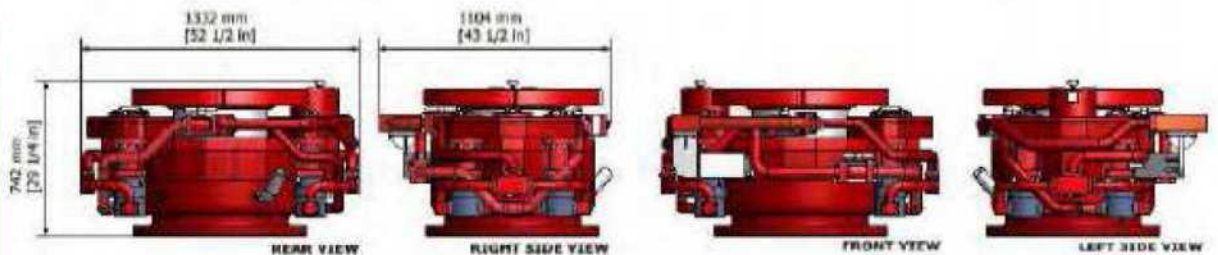
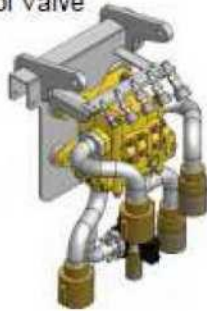

340K HYDRAULIC WORKOVER UNIT PACKAGE MUD PUMP



Mud Pump

Make/Model	Triplex Pump
Horse Power Rating	400 HP and 480 HP
Make/Type	Pyroban 8V92 Turbo
Starter	Air Starter
System Working Pressure	10,000 psi
Liner Size	4 inch
Pump Output	8 bpm.
Rating	Zone 2
Quantity	1 Primary + 1 Backup

340K HYDRAULIC WORKOVER UNIT PACKAGE

150 bbl MUD TANK



Mud Tank

Quantity	3 Unit
Dimension	4500 mm x 2418 mm x 2445 mm
Weight	6500 Kg
Connection	4" Fig 100
Specification	Agitator jets that can be installed and individually controlled via manual valves

340K HYDRAULIC WORKOVER UNIT PACKAGE

25 bbl TRIP TANK



Trip Tank

Quantity	2 Unit
Dimension	2845 mm x 2120 mm x 1860 mm
Weight	3000 Kg
Connection	4" Fig 100

340K HYDRAULIC WORKOVER UNIT PACKAGE

13-5/8" Blow Out Preventer

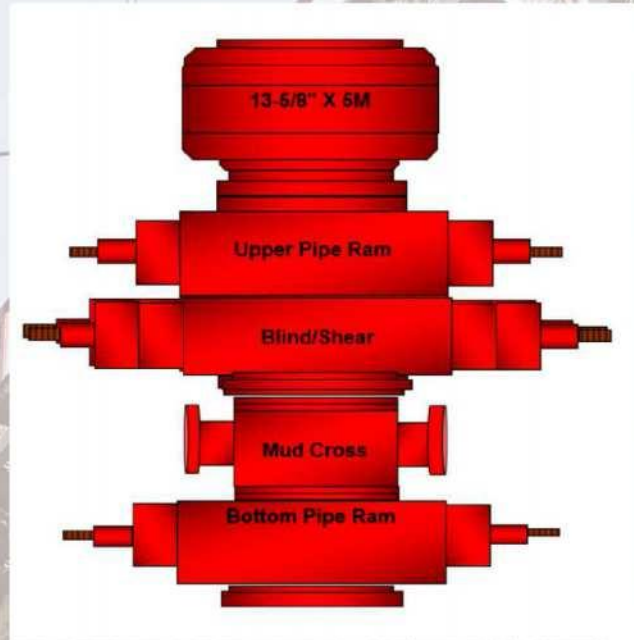

Annular	
Maker	BOMCO, CANSCO AS Assembly
Size / WP	13-5/8" 5M, 5000 psi API 16A
Single RAM	
Maker	Cameron
Size / WP	13-5/8" 5M, 5000 psi API 16A
Double RAM	
Maker	BOMCO, CANSCO RX Assembly
Size / WP	13-5/8" 5M , 5000 psi API 16A
Mud Cross	
Specifications	13-5/8" , 5000 psi, 3-1/8" Flanged Side Outlets
HCR Gate Valve	3-1/8" Flanged x Flanged, API 6A, FC Type
Manual Gate Valve	3-1/8" Flanged x Flanged, API 6A, FC Type

340K HYDRAULIC WORKOVER UNIT PACKAGE

Choke Manifold



Maker	Oil Serve (Jelin Petroleum)
Standard	API 16C
Nominal / Max W.P.	3,000psi / 5,000psi
2-9/16" 10M Hydraulic Choke Valve	1 ea
2-1/16" 5M Gate Valve	7 ea
2-9/16" 5M x 3-1/8" 5M Studded Block	1 ea
3-1/8" 5M Gate Valve	1 ea
3-1/8" 5M Hydraulic Gate Valve	1 ea
2-1/16" 5M Adjustable Choke Valve	1 ea

340K HYDRAULIC WORKOVER UNIT PACKAGE

Choke Manifold



Maker	Oil Serve (Jelin Petroleum)
Standard	API 16C
Max W.P.	10,000psi
Nominal Diameter	2"
End Connection	2" FIG 1502 Union
Working medium	H2S, oil, gas, mud and drilling fluid

340K HYDRAULIC WORKOVER UNIT PACKAGE

Mud Gas Separator



Mud Gas Separator "Poor Boy"

Model Number	: APMGS1000
Diameter	: 1000mm
Flow rate	: 240-300m ³ /Hr
Inlet	: 5"
Discharge	: 8"
Vent line	: 8"
Vessel Height	: 10ft
Design temperature	: -20-100□
Operating temperature	: -20-80□
Design pressure	: 1.0Mpa
Operating pressure	: 1.0Mpa
Hydro test pressure	: 1.2Mpa
Dump valve (bottom)	: 8" butterfly valve
Inspection hatch	: 18"
Mud seal	: 12.5ft
Material	: H ₂ S Resistant
Design	: API 12J
Lifting Pad eyes	: Incorporated

340K HYDRAULIC WORKOVER UNIT PACKAGE

WETSCO 5500 Power Tong

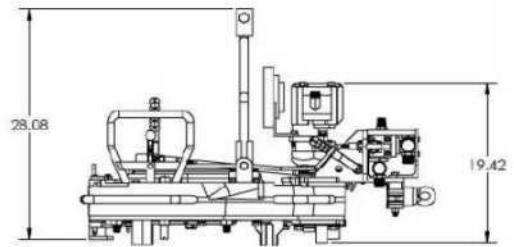
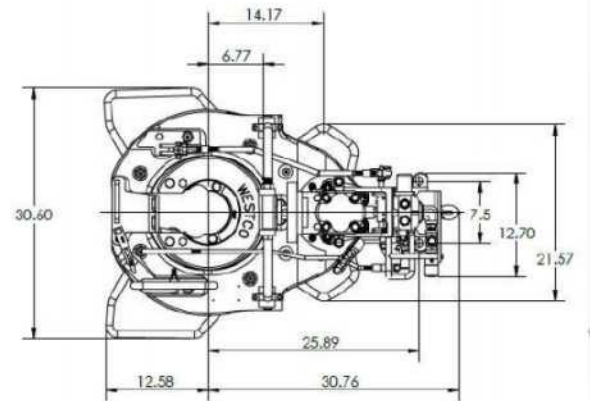

Specification

Pipe Size Range	1.315" to 5-1/2"
Torque	8,740" ft-lbs
Rated Speed	101 rpm
Torque Arm Length	29" (737 mm)
Nominal Power Requirements	2000 psi

340K HYDRAULIC WORKOVER UNIT PACKAGE

Linear Motion Shaker (RL327)



RL327 Base Model Specification (without Feeder)

Overall Dimensions	112 1/8 in. x 74 7/8 in. x 59 in. / 2847mm x 1902mm x 1498mm (L x W x H)
Dry Weight	4,030 lbs. (1,828 Kg)
Lifting Eyes	4 Integrated Welded Pad eyes
Screen Area	27 ft ² (2.508 m ²)
Number of Screens	3 pre-tensioned panels
Screen Clamping	Patented Cam Actuation
G Force	Adjustable up to 7.8 G's

Vibrator Motor

Motor Quantity	2
Motor Horsepower	2.3 HP (1.7 kW)
Standard Voltage	460V, 3 Phase, 60 Hz
Full Load Amps @ 460V	2.95 Amps/ Motor
Motor Lubrication	Permanently Lubricated
Electrical Specification	FM, CSA, CE, ATEX, IECEx
Classification	Class I, Groups C & D / Class II, Groups E & F

340K HYDRAULIC WORKOVER UNIT PACKAGE

Centrifugal Pump



Specification

Overall Dimensions	6.3 ft X 4.3 ft X 5.7 ft (L x W x H)
Dry Weight	2,500 lbs
Pump Model	MCM 250 Series
Pump Size	4 in x 5 in x 14 in (Discharge x Suction x Impeller)
Maximum fluid output	300 gpm (clear water)
Motor Type	Flameproof Marine Induction EX Motor
Model	YB2-160M-4-H
Power / Volt/ Frequency	11kw / 415 V / 60 Hz
RPM	1780
Protection Class	IP56

340K HYDRAULIC WORKOVER UNIT PACKAGE

Rotary and Casing Slip

SDML & SDXL Rotary Slips

For use in API standard insert bowls.

- Buttress design of the body segments provides great strength while minimalizing weight for ease of handling

Slip Size (in)	API Pipe Size ID (in)
3, 1/2	2, 3/8
	2, 7/8
	3, 1/2
4, 1/2	3, 1/2
	4
5	4, 1/2
	4
5, 1/2	4, 1/2
	5
	5, 1/2
7	6, 5/8
	7



SDXL SLIP

SDML & SDXL Rotary Slips

Available to handle any casing job

- Manufactured from drop forgings, reinforced to take severe service
- Self-centering full wraparound grip prevents damage to casing
- Can accommodate casing from 6-5/8" to 36" OD



CMS-XL SLIP